

**LORCH**  
smart welding



# YOUR HELMET: THE APR 900 PLUS.

Your PLUS in safety  
and comfort.

[www.apr900.com](http://www.apr900.com)

**NEW:** Extra-large viewing window  
and ISO 16-321-2 certified glare  
protection cassette.

# It's **YOUR** helmet!

You are placing high demands on your helmet. It must be easy to use, it needs to adapt to you, it needs to be safe, and it has to protect your health. On top of that, it should also look good on you.

The APR 900 PLUS as a standard and fresh-air system is going to meet all your requirements:

## Security

No matter in which direction you are facing, whether overhead, lying down or sideways, or for any position in between. With reliable darkening precisely to your needs.

## Clear vision

A perfect view of the welding result requires a large field of vision, ideal colour reproduction and fast shutter speed of the auto darkening filter.

## Flexibility

Easy replacement of wear parts, adjustment options for the visual appearance to personal preferences, and expansion with numerous accessories – from chest to neck protectors.

## Longevity

and robustness are required in everyday welding work. It's even better if the helmet design is also cool and makes you look good.

## Ergonomics

Balanced, perfectly fitting, with adjustment options for fatigue-free welding even when worn for prolonged periods.

## Price-performance ratio

Because safety must not be a privilege!



**“I am convinced  
of the  
APR 900 PLUS.”**

**Martin John**  
Application engineer

I am using it every day, and it is proving its incredible performance. The easy and flexible handling of the helmet are of great benefit – I can switch from welding mode to grinding mode very quickly even with gloves on.

The APR 900 PLUS is practical; it fits perfectly and makes me feel secure. You only have two eyes in your life. You need to protect them without accepting any compromises!

# IT FITS YOU PERFECTLY.

Work safety as you need it.

## The APR 900 PLUS welding helmet

The helmet is at the core of workplace safety by Lorch. The APR 900 combines all technical features that a state-of-the-art welding helmet needs. On top of this: It also looks good.

**The APR 900 PLUS is all you need.**



APR 900 PLUS  
standard helmet

APR 900 XF PLUS  
with flip mechanism

## The APR 900 PLUS fresh-air system

Are you a professional welder looking for the perfect helmet and breathing protection system? Supplemented by smart accessories that make working with fresh air easier and allow you to produce perfect welding results over the long term? **The APR air PLUS fresh-air system is your first choice then.**



APR 900 air PLUS  
with breathing protection system

APR 900 XF air PLUS  
with breathing protection system  
and flip mechanism



APR FLOW



APR FLOW ACCESSORIES

## The professional helmet for professional welders. **THE APR 900 PLUS.**

A helmet that is completely designed around you, supports you in your work and offers you maximum safety. 100% your helmet. Your helmet not only comprises an auto darkening filter at an absolute reference level, but also includes many other practical detail solutions that are absolutely harmoniously combined in an overall concept.

### The protection levels

**Highest safety rating for welding helmets:** The helmet shell meets the requirements of the European standards EN 175 B.



### The "four-point support"

**Safe storage, perfect handling, optimal scratch protection:** Even the best auto darkening filter will become useless if a scratched front cover only reflects the arc. Your helmet can be placed easily with the visor side down. The visor will still be protected from contact and scratches.

Nice side effect: The sweatbands in the headband are protected from dust and dirt on surfaces and dry quickly.

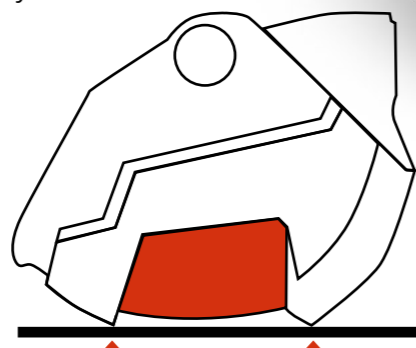

### The grinding button

**Dedicated grinding button at the helmet centre:** Centrally mounted rubberised grinding button in easy-to-find position, even left-handed. This way, you can switch to grinding mode without having to take off your helmet. The recessed position protects it well from damage.

### The new glare protection cassette L860

**Viewing window extended downwards with 82 x 100 millimetre viewing area:** Now guarantees an even better view of the workpiece and surroundings. The welder can hold his head upright more easily during welding. The improved posture prevents neck problems.

### Complete flexibility for the perfect fit

**Extensive adjustment options for any head:** Head circumference adjustment via a ratchet-fastening knob at the back of the head, double strap construction for an integrated, stable fit, and longitudinal helmet adjustment to adjust to the shape of your face and your preference.

**Sweatbands for the forehead and back of the head:** Individual absorbent and padded sweatbands around the headband.

**Locking in the upper and lower position:** The helmet latches in the upper and lower settings to keep it in the respective position. The "speed" at which the helmet closes again can be adjusted independently of this.

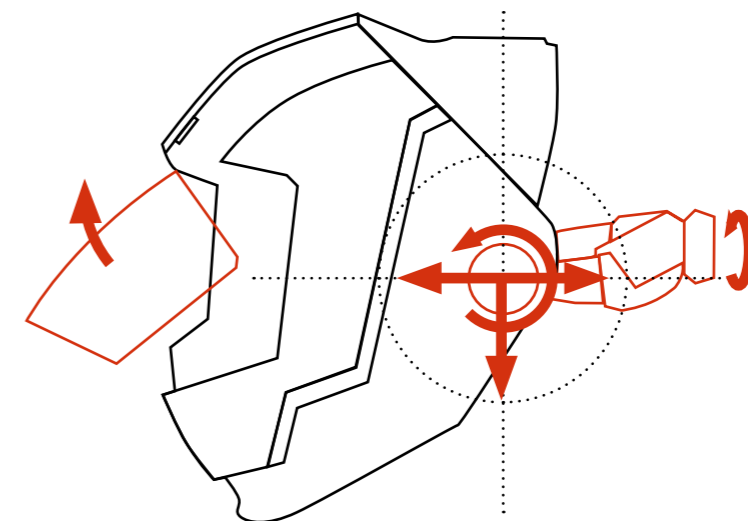

**Outer front cover made of robust injection moulding with innovative quick-release fastener:** Improved sealing protects the cassette and increases its service life. Highest achievable optical class. Certified according to ISO-16321-2.

# Larger field of vision. More functions. **EVERYTHING IN VIEW WITH THE NEW GLARE PROTECTION CASSETTE.**

THE **PLUS** FOR SAFETY AND COMFORT.



**Battery life:**  
3,000 h battery life with standard CR2450 battery. The batteries are protected from dust inside the housing.

**Accessories:**  
Special attachment lens with yellow tint to imitate the 'soft' colour impression of classic glare protection cassettes.  
Dioptre discs for 1.0x/1.5x and 2.0x magnification.

Better eye protection in the long term.

New glare protection cassette at the highest quality level and in the absolute reference range V1, extra large field of vision and very wide protection level range (3, 5-9, 10-14). Certified to ISO 16321-2. True Colour of the 2nd generation significantly limits UV light and blue light. Reliable function in high-frequency pulsating applications thanks to 6 sensors (4 arc and 2 light intensity sensors).

Reduces the risk of fatigue, headaches and long-term retinal damage.



New practical control panel.

**Simple operation and operating modes:** Depending on the application, the operating modes and protection levels, delay and sensitivity can be easily set using the control panel in the lower section of the cassette. Welding mode (protection level 10-14), grinding mode (protection level 3) and cutting mode (protection level 5-9) are available for selection.

For even more convenience and fewer interruptions during welding, additional functions can now be activated:

### Soft Delay

**The new delay option** ensures that the eye can slowly adjust to the brightness of the open cassette by gradually opening the cassette. This means that unpleasant glare – caused by the afterglow of the weld seam, for example – is a thing of the past

### Spot Delay

**Specially developed for tack welding:** Reduces the change from light to dark by gradually opening the cassette, allowing the eye to adjust slowly. This makes work much more pleasant for the welder and reduces eye fatigue.

### Auto Shade

**Optimum visibility for long seams or welding around corners:** Depending on the light intensity of the arc, the protection level is continuously and automatically regulated between light and dark and also adjusted during welding. This ensures optimum visibility at all times for long and complex weld seams and large components.

# THE APR 900 XF PLUS.

## Clearest view on full width.

A flip helmet is ideal, in particular if other work is required in addition to welding where the eyes and face must be protected from dust and sparks. It combines the large and clear view of a grinding visor with the automatic protection from the UV radiation of the arc. The helmet can stay on your head and be folded up or down depending on the work task.

“XF” – for the  
eXtra Flip mechanism

**Safety and comfort:** The two-part helmet contains a large curved protective lens with a large field of vision. This protects from flying particles and sparks, such as those produced during grinding. An outer helmet shell containing the glare protection cassette can be folded down.

Easy handling

**The outer and inner helmet shells are disconnected from each other.** The disconnected folding mechanism ensures that the inner helmet shell remains closed even when the outer shell is unfolded. This allows one-handed activation of a large, clear field of vision with maximum protection.

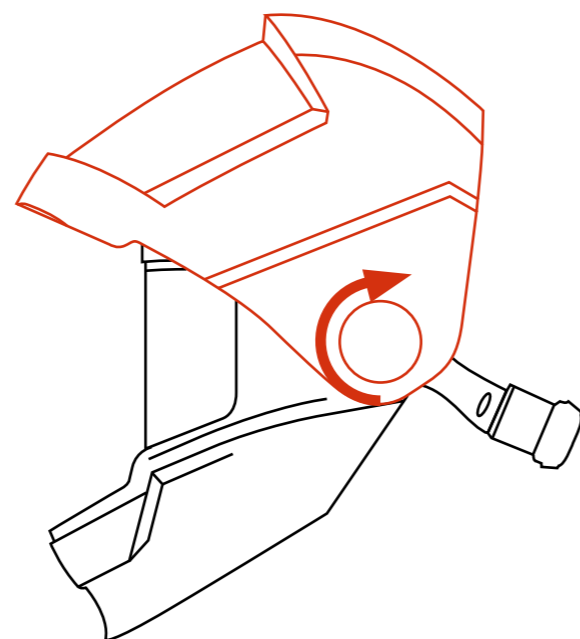

Perfect vision – thanks to large grinding visor

**A large viewing window offers greater peripheral vision.** There is no need to move the head as frequently. Movements or even potential danger in the peripheral area can be perceived early.

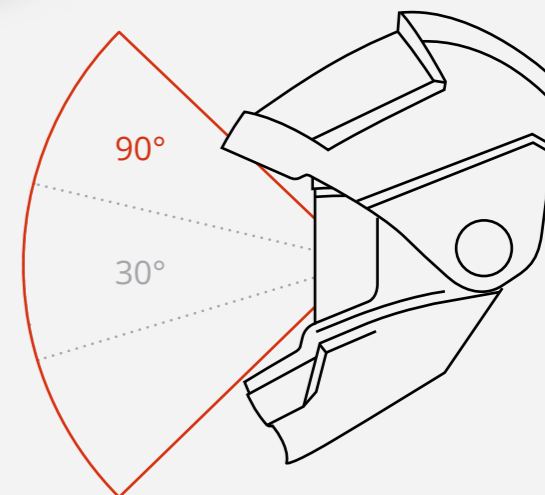
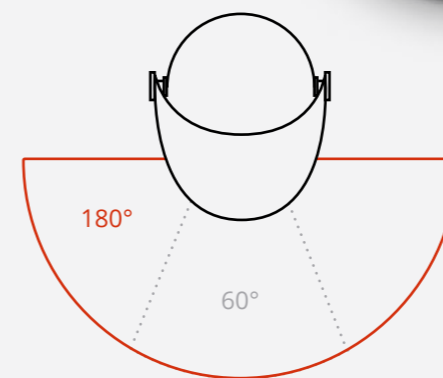

..... without flip mechanism  
— APR 900 XF PLUS (with open visor)

# Fresh air and comfort in every welding position. **THE APR 900 AIR PLUS SYSTEM.**



## Pleasant fresh air

**Draught-free ventilation, comfortable, and quiet.** The air flow supplied does not create an issue on the eyes or ears and is also supplied to the interior of the helmet without whistling or noise. Full enjoyment of the fresh-air supply without restrictions.



## Adjustable air supply

**The air supply adjuster allows adjustment of the air flow** – only to the mouth/nose area in the closed position and additionally to the forehead in the open position. The welder can adjust the direction of ventilation depending on individual preferences. Reliable fume shielding is warranted in all positions via the overpressure in the helmet.

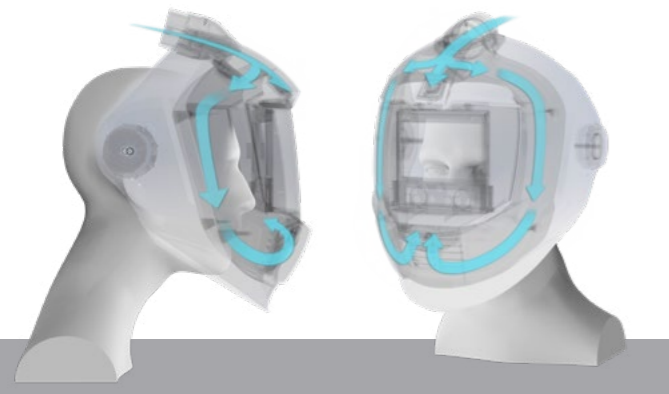

## Draft-free air distribution

The supply air exits in a diffuse stream in the area of the mouth and nose without tiring the eyes. The dial switch for additional air supply to the forehead adds some extra comfort.

The illustration shows the **APR 900 air PLUS** with the **fresh-air unit APR FLOW** (see the following pages)

## THE APR 900 XF AIR PLUS

Perfectly prepared for the APR FLOW.





# Tried and tested. **COMFORT AND PROTECTION WHERE IT COUNTS.**

## Wearing comfort

**The lightweight fan and filter unit will adjust to the shape of your back to be barely perceptible.** The support system is soft yet stable enough to ensure that the unit sits tightly on the back and does not dangle between the legs, preventing you from working.

## Ventilation hose with quick-release bayonet fastener and hose holder

**Easy and quick assembly and disassembly of the helmet and hose.** The helmet separates quickly from the ventilation system. Particularly useful when the helmet needs to be put aside without taking off the strap. The helmet can also be used without the ventilation system. The hose holder on the headband ensures that the hose is fixed, can be individually guided, and does not interfere with work.

## Effective sealing and a comfortable fit

**The better the seal between the helmet and the welder's face, the less smoke can penetrate.** The improved face seal with collar seals the helmet from below and prevents unfiltered ambient air from entering via the throat and neck area. The fire-resistant soft fleece material is comfortable against the skin. Thanks to an industrial Velcro fastener, the seal can be replaced quickly and without tools.

# The perfect combination. THE APR FLOW BREATHING PROTECTION.



## Contemporary USB-C charging socket

We surely all remember it: The mobile phone ran out of battery and no fitting charging cable at hand... **USB-C is always available today, making sure that the APR Flow can be charged at all times.** The socket is dust-protected inside the housing.

## Particle or gas filter?

**A PRSL particle filter is usually sufficient in good working conditions with good to limited ventilation.** However, if aluminium or stainless steel are to be welded with limited ventilation, an additional ABE1 gas filter with activated carbon filter quickly becomes necessary in order to comply with the limit values according to the risk assessment. The APR Flow offers both options to secure its contribution to safeguarding health and working capacity for a long time to come.

## Certified health protection.

Our APR 900 air PLUS systems are TH3 certified – for particle filters and even for gas filters! Only the highest protection class TH3 will filter out 99.8% of all harmful particles and gases. This makes the air 10 times cleaner than the TH2 respiratory protection systems that are common on the market can manage!



## No compromise in the area of safety

**Battery capacity and filter clogging are displayed by LEDs during operation, enabling timely preparation of the unit.** If this is missed, the APR Flow first sounds an acoustic alarm and later a vibration alarm as well, prompting to leave the danger zone in time and without any risk of misunderstandings.

## Tough conditions?

**Welding times until recharging can be doubled with an optional heavy-duty battery.** This is perfect for longer tasks or on external assembly jobs. There is the protective cover for the ventilation hose, which protects it from damage for a longer service life and frequent welding in constrained positions.

## Are you not quite convinced yet?

**The APR Flow can also be retrofitted to the APR 900 air PLUS and APR 900 XF air PLUS.** Allowing you to test helmets individually and simply connect them later on.

# APR 900 PLUS welding helmets

Welding helmet APR 900 PLUS and XF PLUS  
with ADF APR L860 auto darkening filter



## APR 900 PLUS

Field of vision	100 x 82 mm / 3.94" x 3.3"
Classification	V1 (optical category, scattered light, homogeneity, angular dependence)
True colour vision	Yes
Grinding mode	Yes (can be switched from the outside via central grinding button)
UV/IR protection	Durable protection level DIN 14
Protection level (light   dark)	Protection level DIN 3   DIN 5-8 (cutting) / DIN 9-14 (welding)
Switching time (light to dark)	0.2 ms at room temperature   0.1 ms at +55 °C
Sensor technology	4 sensors (arc detection) + 2 sensors (arc intensity)
Sensitivity control	Digital (1-9)
Delay control	Digital (0,1 s - 0,95 s)
TIG rating	>2A
Power supply	1 x CR 2450 (exchangeable)
Battery life	>2,000 hours (operation)
On/Off	Fully automatic
Operating   Storage temperature	-5 °C to +55 °C / 23 °F to 131 °F   -20 °C to +70 °C / -4 °F to 158 °F
Standards and norms	EN ISO 16321-1:2022 ANSI Z87.1-2020 CSA Z94.3-2020 AS/NZS 1338.1-2012
Total weight of the helmet	650 g
Application areas*	Electrode welding (stick welding, SMAW) / MIG-MAG shielded metal arc welding, GMAW) / GMAW high performance welding / flux cored welding / TIG welding (TIG, GTAW) / plasma welding / micro-plasma welding / plasma cutting / grinding.
Scope of supply	1x APR 900 welding helmet, 1x front cover, 1x inner protective screen, 1x cleaning cloth, 1x battery, 1x operating manual

\* For all electric welding processes. Suitable for overhead welding. Not suitable for laser welding!



## APR 900 XF PLUS (in addition to the APR 900 PLUS)

Grinding mode	Flip-up mechanism instead of grinding button
---------------	--

# APR 900 air PLUS fresh-air systems

Supplementary data of the APR 900 air PLUS, XF air PLUS  
with automatic glare protection cassette ADF APR L860  
and fresh-air unit APR FLOW



## APR 900 air PLUS (in addition to the APR 900 PLUS)

Air distribution	adjustable
------------------	------------



## APR 900 XF air PLUS (in addition to the APR 900 PLUS)

Grinding mode	Flip-up mechanism instead of grinding button
Air distribution	adjustable



## APR FLOW

Air flow	adjustable from 170 to 220 l/min
Lithium-ion battery	Up to 8 hours of operation at 220 l/min (PRSL only). Optional heavy-duty version up to 10+ hours of operation at 220 l/min (PRSL only)
Pre-filter	interchangeable with spark arrestor
Particle filter	PRSL, TH3 (EN12941)
Gas filter (optional)	ABE1 + PRSL, TH3 (EN12941)
Charger	USB-C and power plug international with interchangeable pins
Charging time	4-6 hours standard battery, 4-6 hours heavy-duty battery
Recognition	Filter status, battery level
Status warning	optical, acoustic, via vibration
Shoulder strap	optional
Scope of supply	1x APR Flow, 2x particle filter (installed), 1x pre-filter (installed), 1x standard Li-Ion battery, 1x ventilation hose, 1x carrying strap, 1x charger, 1x operation manual

# YOUR HELMET: THE APR 900 PLUS.

Experience the advantages of the APR 900 PLUS as a standard helmet,  
with flip mechanism as well as our fresh-air system, up close:  
Flexible. Secure. Individual.

**Your contact:**



**More info also available on**  
[www.apr900.com](http://www.apr900.com)

913.1288.1 | EN | 02.2026 | Subject to technical changes, price changes, and printing errors.

Lorch Schweißtechnik GmbH  
Im Anwänder 24-26 · 71549 Auenwald · Germany  
T +49 7191 503-0 · F +49 7191 503-199  
[info@lorch.eu](mailto:info@lorch.eu) · [www.lorch.eu](http://www.lorch.eu)

**LORCH**  
smart welding