

# EX-TRAFIRE® 65HD

INDUSTRIAL CUTTING. HEAVY-DUTY PERFORMANCE.



CUTTING  
**65 A**  
CURRENT

MATERIAL  
**30 mm**  
THICKNESS

VARIOUS  
OPERATION  
**MODES**



Automotive  
and transportation



Energy



Structural



Education  
and Training



Craft, hobby and  
non industrial users

# EX-TRAFIRE® 65HD

## SPECIFICATIONS

Output current [A]	10 -65
Modes	standard cutting / grid cutting / gouging / marking
Duty cycle	100 % @ 65 A
Rated output voltage [VDC]	170
Severance cutting capacity [mm]	30 <sup>(1)</sup>
Piercing capacity [mm]	18 <sup>(1)</sup>
Recommended cutting capacity [mm]	18 <sup>(1)</sup>
Plasma gas	compressed air / nitrogen / argon
Max. Air flow (cutting) [lpm/bar]	195/5.2
CNC interface / Serial (RS/CAN bus)	Built - In / optional
Preadjusted voltage divider ratio	50:1
Input voltage [VAC]	3 × 400 ± 15 % <sup>(2)</sup>
Frequency [Hz]	50/60
Dimensions (L × H × W) [mm]	560 × 400 × 260
Weight [kg]	20.4
Certification depending on region	CE
Maximum input pressure [bar/psi]	10/145
Protection level	IP23S
Insulation class	F
Type of hand torch	FHT-EX®105TTH
Type of machine torch	FHT-EX®105TTM

<sup>(1)</sup> Values for low alloy steel, E. G. MS S235JR

<sup>(2)</sup> Suitable for generator use



### 4 DIFFERENT OPERATION MODES

The plasma cutting systems in the EX-TRAFIRE®HD range are the absolute specialists in meeting tough demands in continuous operation. The mobile EX-TRAFIRE®65HD plasma cutting system with 100% duty cycle is the perfect solution for demanding heavy duty applications in industry.

- CUTTING
- GRID CUTTING
- MARKING
- GOUGING

Last update of this page: 10/01/2025. See Revision history for details.  
For product availability, please check with your local THERMACUT® dealer.

# EX-TRAFIRE® 65HD

## ORDERING INFORMATION

Description	Length	Part No.
<b>MANUAL PLASMA CUTTING SYSTEMS (STANDARD EQUIPPED)</b>		
<i>Standard (STD) - equipped = CNC interface</i>		
EX-TRAFIRE®65HD/CE/3x400 V / Torch FHT-EX®105TTH /Starter Kit	5 m / 16.4'	EX-3-010-051
EX-TRAFIRE®65HD/CE/3x400 V / Torch FHT-EX®105TTH /Starter Kit	8 m / 26.2'	EX-3-010-052
EX-TRAFIRE®65HD/CE/3x400 V / Torch FHT-EX®105TTH /Starter Kit	15 m / 49.2'	EX-3-010-053
<b>MECHANIZED PLASMA CUTTING SYSTEMS (FULLY EQUIPPED)</b>		
<i>Fully-equipped = CNC interface &amp; Serial interfaceport (RS/CAN bus)</i>		
EX-TRAFIRE®65HD/CE/3x400 V / Torch FHT-EX®105TTM STD-NR /Starter Kit	8 m / 26.2'	EX-3-011-014
EX-TRAFIRE®65HD/CE/3x400 V / Torch FHT-EX®105TTM STD-NR /Starter Kit	15 m / 49.2'	EX-3-011-015
EX-TRAFIRE®65HD CE 3x400 V / Torch FHT-EX®105TTSM /Starter Kit	8 m / 26.2'	EX-3-012-006
EX-TRAFIRE®65HD CE 3x400 V / Torch FHT-EX®105TTSM /Starter Kit	15 m / 49.2'	EX-3-012-007
<b>MECHANIZED PLASMA CUTTING SYSTEMS (STANDARD EQUIPPED)</b>		
<i>Standard (STD) - equipped = CNC interface</i>		
EX-TRAFIRE®65HD/CE/3x400 V / Torch FHT-EX®105TTM STD-NR /Starter Kit	8 m / 26.2'	EX-3-013-002
EX-TRAFIRE®65HD/CE/3x400 V / Torch FHT-EX®105TTM STD-NR /Starter Kit	15 m / 49.2'	EX-3-013-003
EX-TRAFIRE®65HD CE 3x400 V / Torch FHT-EX®105TTSM /Starter Kit	8 m / 26.2'	EX-3-014-002
EX-TRAFIRE®65HD CE 3x400 V / Torch FHT-EX®105TTSM /Starter Kit	15 m / 49.2'	EX-3-014-003
<b>PLASMA CUTTING UNITS (FULLY EQUIPPED)</b>		
<i>Fully-equipped = CNC interface &amp; Serial interfaceport (RS/CAN bus)</i>		
EX-TRAFIRE®65HD/CE/3x400 V power supply unit		EX-3-001-002
<b>PLASMA CUTTING UNITS (STD EQUIPPED)</b>		
<i>Standard (STD) - equipped = CNC interface</i>		
EX-TRAFIRE®65HD/CE/3x400 V power supply unit		EX-3-003-001

## AVAILABLE BULK PACKS

Information about available bulk packs on the end of Torch Consumables section

## AVAILABLE STARTER KITS

Information about available starter kits on the end of Torch Consumables section

## ACCESSORIES

Information about available accesories on the last pages of this section

Last update of this page: 10/01/2025. See Revision history for details.  
For product availability, please check with your local THERMACUT® dealer.

# FHT-EX® 105TT



## THE ALL-NEW CUTTING TORCH

+ HANDHELD  
+ MECHANIZED



The high-performing FHT-EX®105TT H/M hand and machine torches meet the tough demands of continuous operations. Designed for optimal use with 105HD power supply for cutting, gouging, grid-cutting and marking, while allowing cut thickness up to 50 mm with greater precision and speed.

Thanks to the THERMACUT® Torch Connection System (TCS), changing the torch is a quick and easy process. The powerful torches are the result of decades of experience in the field of plasma cutting. They feature an extremely robust and durable design in which all consumables can be replaced quickly and easily.

### BENEFITS

- High-performant torches for mechanised applications and handheld use
- Ergonomic handheld torches for safe and reliable holding and guiding in all positions
- Compact and flexible for handheld applications, even in the case of tight radii or gouging of fillet welds
- 100 % duty cycle at 65 A, ideal for continuous use
- Optimal for plate thicknesses of up to 30 mm, thanks to high power reserves
- Consumables with an extended lifetime
- Quick and tool-free replacement of consumables
- Piercing 18 mm
- Perfectly designed for use with EX-TRAFIRE®105HD power supplies

Last update of this page: 10/01/2025. See Revision history for details.  
For product availability, please check with your local THERMACUT® dealer.

# FHT-EX® 105TTH

## HAND TORCH ASSEMBLY

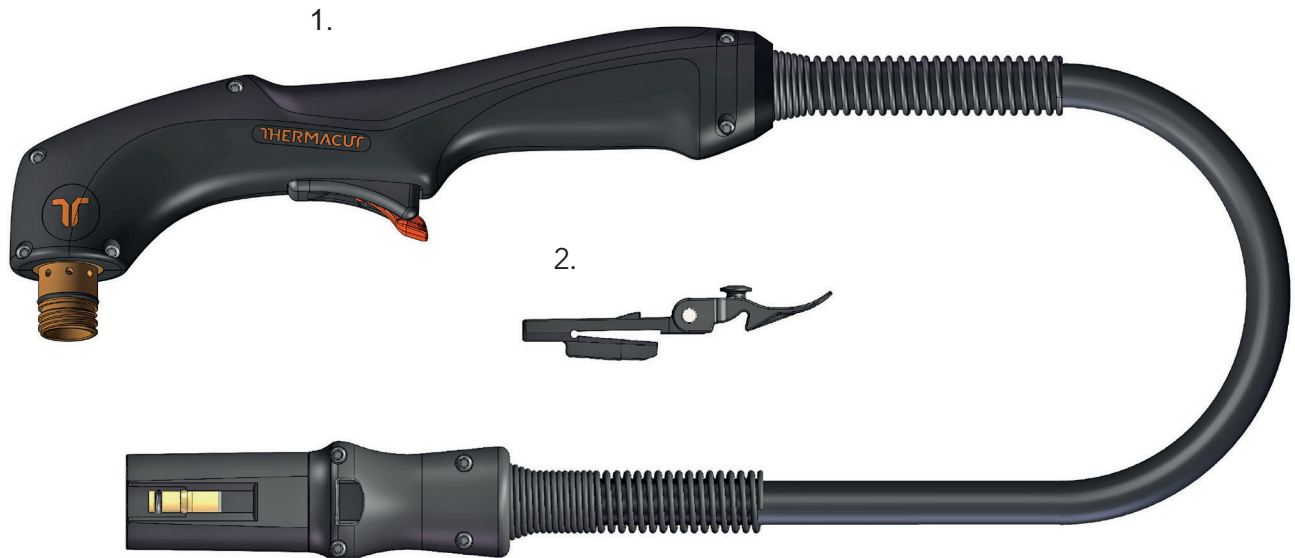

Item	Part No.	Description	Pcs
1.	EX-5-133-002	DEMO FHT-EX®105TTH Hand Torch Assembly/TCS13	1
	EX-5-139-001	FHT-EX®105TTH Hand Torch Assembly-w/o consumables w/5m (16.5') Lead/TCS13	1
	EX-5-139-002	FHT-EX®105TTH Hand Torch Assembly w/o consumables w/8m (26') Lead/TCS13	1
	EX-5-139-003	FHT-EX®105TTH Hand Torch Assembly w/o consumables w/15m (50') Lead/TCS13	1
	EX-5-139-004	FHT-EX®105TTH Hand Torch Assembly w/o consumables w/23m (75') Lead/TCS13	1
a2.	EX-0-321-003	Latch with Key Assembly	1

**a** LATCH WITH KEY IS NOT CONTENT OF TORCHES ABOVE. IF YOU NEED IT, YOU HAVE TO ORDER SEPARATELY.

Last update of this page: 10/01/2025. See Revision history for details.  
For product availability, please check with your local THERMACUT® dealer.

# FHT-EX® 105TTH

## HAND TORCH COMPONENTS



Item	Part No.	Description	Pcs	Item	Part No.	Description	Pcs
1.	EX-5-374-010	FHT-EX®105TTH Hand Torch Lead Replacement 5m (16.5')/TCS13	1	9.	EX-0-323-001	TCS13 Plug Body	1
1.	EX-5-374-011	FHT-EX®105TTH Hand Torch Lead Replacement 8m (26')/TCS13	1	10.	EX-5-302-001	Hand Torch Body Repl. Kit (incl. Torch body & Cap sensor)	1
1.	EX-5-374-012	FHT-EX®105TTH Hand Torch Lead Replacement 15m (50')/TCS13	1	11.	EX-5-431-050	O-Ring (fitted on the torch body) - 2 pcs	2
1.	EX-5-374-013	FHT-EX®105TTH Hand Torch Lead Replacement 23m (75')/TCS13	1	12.	EX-5-314-001	Hand Torch Handle Replacement Kit	1
2.	EX-5-318-001	TCS Plug Spring Strain Relief	1	13.	EX-5-305-002	Cap-sensor Replacement Kit with Screws/ Hand Torch	1
3.	EX-0-325-015	TCS Clam Shell Screw Kit (incl. 4 screws)	1	14.	EX-5-313-031	Safety Trigger	1
4.	EX-0-325-002	TCS Clam Shell Upper	1	15.	EX-5-308-001	Hand Torch Handle with Screws	1
5.	EX-0-325-001	TCS Clam Shell Lower	1	16.	EX-5-372-010	Cathode mounting kit	1
6.	EX-0-325-010	Retaining Ring (Outer circlip ring)	1	a 17.	EX-0-321-003	Latch w/Key Assembly	1
7.	EX-0-325-009	O-Ring (fitted in the TCS plug)	1	18.	EX-5-313-030	Safety Trigger Micro-Switch	1
8.	EX-0-325-005	Male Crimp Pin for TCS Plug	1				

**a** LATCH WITH KEY IS NOT CONTENT OF TORCHES ABOVE. IF YOU NEED IT, YOU HAVE TO ORDER SEPARATELY.

Last update of this page: 10/01/2025. See Revision history for details.  
For product availability, please check with your local THERMACUT® dealer.

# CONSUMABLES

## HAND TORCH CONSUMABLES - 45-65 A

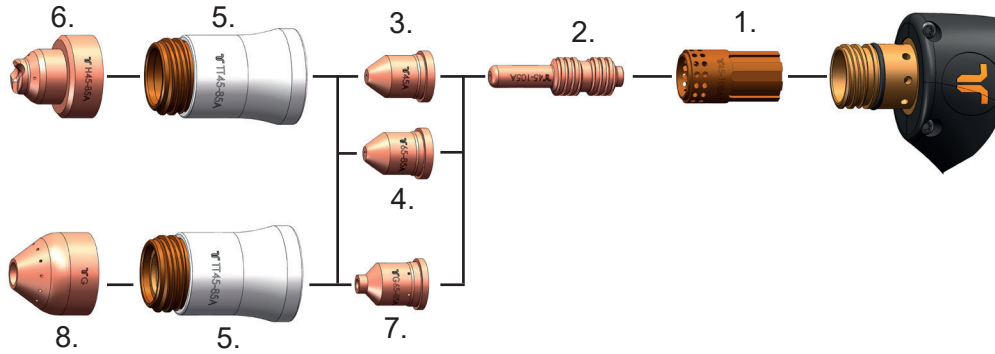

Item	Part No.	Description	Pcs	Item	Part No.	Description	Pcs
1.	EX-5-404-052	Swirl Ring 45-105 A	1	5.	EX-5-415-050	Nozzle Retaining Cap 45-85 A	1
2.	EX-5-401-051	Electrode 45-105 A	5	6.	EX-5-422-031	Hand Shield 45-85 A	1
3.	EX-5-410-051	Nozzle 45 A	5	7.	EX-5-440-051	Gouging Nozzle 65-85 A	5
4.	EX-5-410-053	Nozzle 65-85 A	5	8.	EX-5-440-050	Gouging Shield	1

Last update of this page: 10/01/2025. See Revision history for details.  
For product availability, please check with your local THERMACUT® dealer.

# CONSUMABLES

## HAND TORCH CONSUMABLES - SMOOTHLINE

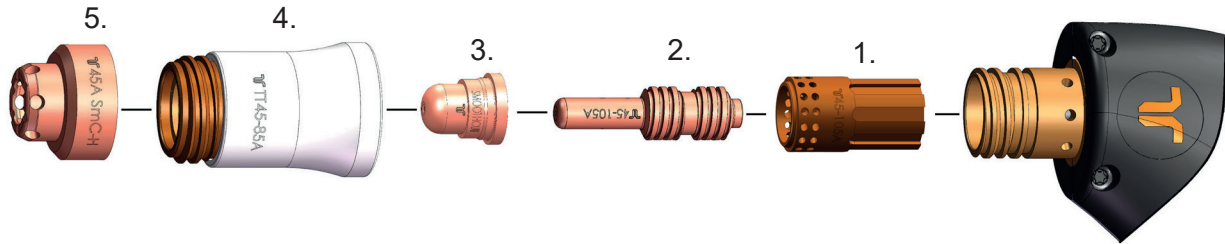

Item	Part No.	Description	Pcs
1.	EX-5-404-052	Swirl Ring 45-105 A	1
2.	EX-5-401-051	Electrode 45-105 A	5
3.	EX-5-410-050	Nozzle Smoothline	5
4.	EX-5-415-050	Nozzle Retaining Cap 45-85 A	1
5.	EX-5-420-050	Hand Shield 40/45 A Smoothline	1

Last update of this page: 10/01/2025. See Revision history for details.  
For product availability, please check with your local THERMACUT® dealer.

# FHT-EX® 105TTM

## MACHINE TORCH ASSEMBLY

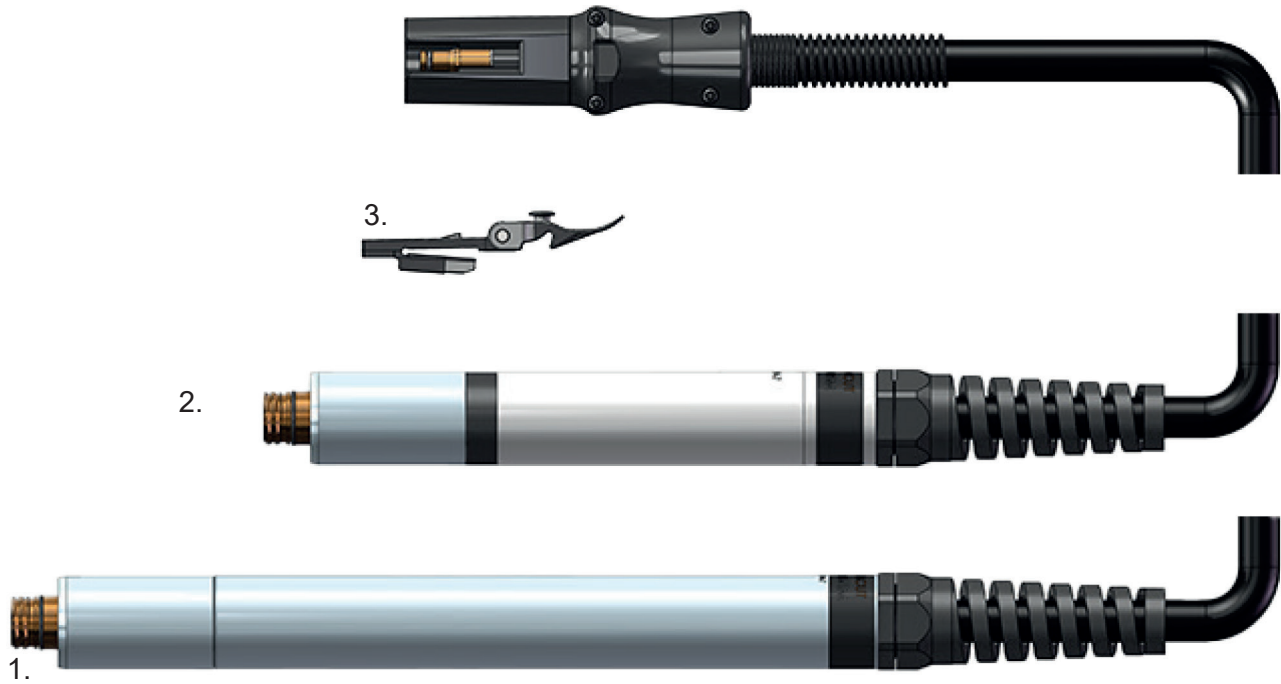

Item	Part No.	Description	Pcs
1.	EX-5-202-031	FHT-EX®105TTM M Torch Assy w/o consumables w/5m (16.5')Lead/ TCS13	1
1.	EX-5-204-031	FHT-EX®105TTM M Torch Assy w/o consumables w/8m (26') Lead/ TCS13	1
1.	EX-5-207-032	FHT-EX®105TTM M Torch Assy w/o consumables w/15m (50') Lead/ TCS13	1
1.	EX-5-210-034	FHT-EX®105TTM M Torch Assy w/o consumables w/23m (75') Lead/ TCS13	1
NS	EX-5-233-020	DEMO FHT-EX®105TTM (STD) Machine Torch Assembly/TCS13	1
2.	EX-5-242-021	FHT-EX®105TTSM Short Machine Torch Assembly-w/o consumables w/5m (16.5') Lead/ TCS13	1
2.	EX-5-244-021	FHT-EX®105TTSM Short Machine Torch Assembly-w/o consumables w/8m (26') Lead/ TCS13	1
2.	EX-5-247-021	FHT-EX®105TTSM Short Machine Torch Assembly-w/o consumables w/15m (50') Lead/ TCS13	1
2.	EX-5-250-021	FHT-EX®105TTSM Short Machine Torch Assembly-w/o consumables w/23m (75') Lead/ TCS13	1
NS	EX-5-234-021	DEMO FHT-EX®105TTSM Short Machine Torch Assembly/ TCS13	1
a	3.	EX-0-321-003 Latch with Key Assembly	1

a LATCH WITH KEY IS NOT CONTENT OF TORCHES ABOVE. IF YOU NEED IT, YOU HAVE TO ORDER SEPARATELY.

Last update of this page: 10/01/2025. See Revision history for details.  
For product availability, please check with your local THERMACUT® dealer.

# FHT-EX® 105TTM

## MACHINE TORCH COMPONENTS

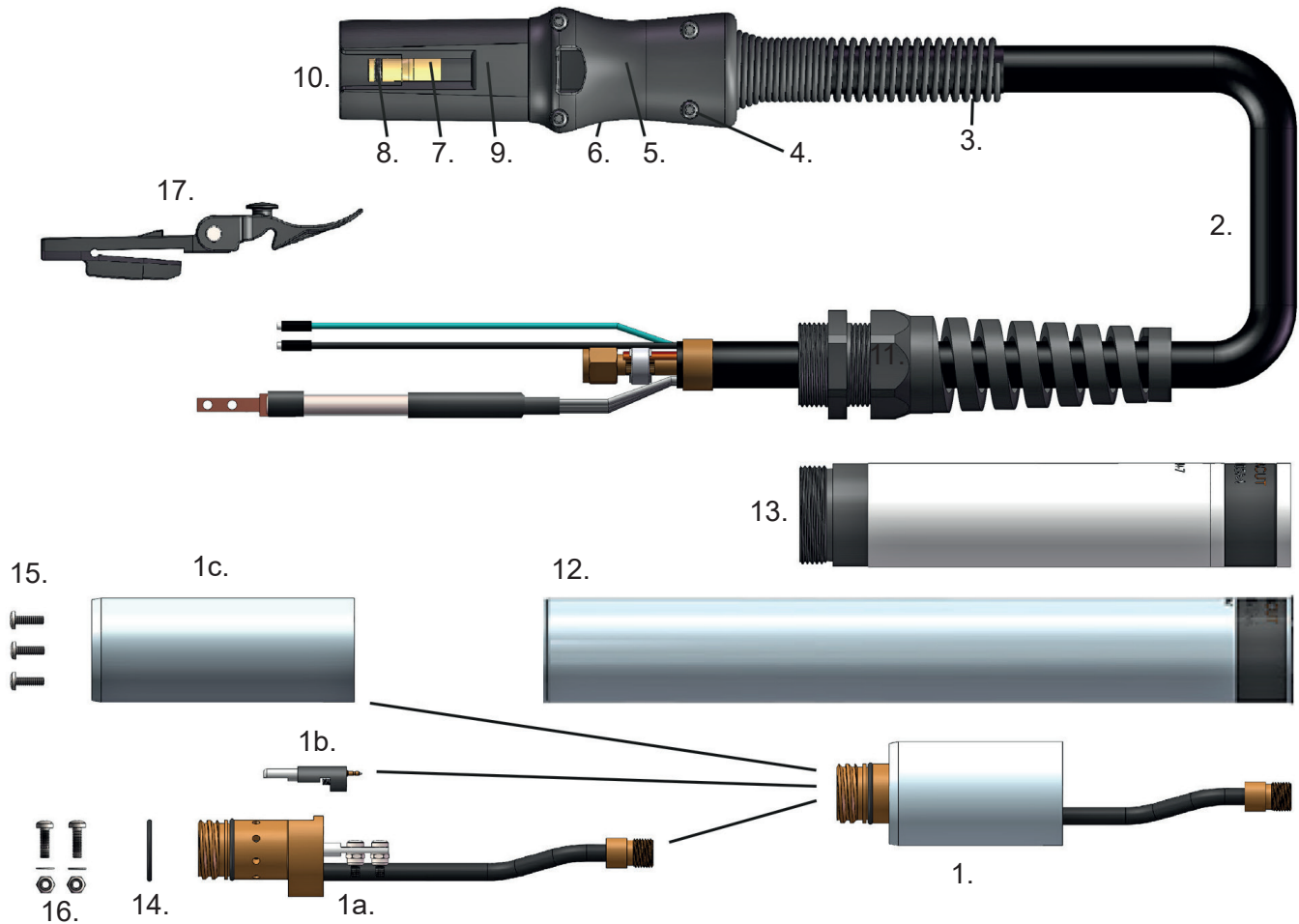

Item	Part No.	Description	Pcs	Item	Part No.	Description	Pcs
1.	EX-5-303-011	Machine Torch Body Assembly FHT-EX®105TTM	1	6.	EX-0-325-001	TCS Clam Shell Lower	1
1a.	EX-5-303-010	Machine Torch Body FHT-EX®105TTM	1	7.	EX-0-325-010	Retaining Ring (Outer circlip ring)	1
1b.	EX-5-304-001	Cap Sensor Replacement Kit with Screws/Machine Torch	1	8.	EX-0-325-009	O-Ring (fitted in the TCS plug)	1
1c.	EX-5-306-002	Torch Mounting Sleeve (incl. 3 screws)	1	9.	EX-0-325-005	Male Crimp Pin for TCS Plug	1
2.	EX-5-375-010	FHT-EX®105TTM Machine Torch Lead Replacement 5m (16.5')/TCS13	1	10.	EX-0-323-001	TCS13 Plug Body	1
2.	EX-5-375-011	FHT-EX®105TTM Machine Torch Lead Replacement 8m (26')/TCS13	1	11.	EX-5-317-021	Machine Torch Strain Relief	1
2.	EX-5-375-012	FHT-EX®105TTM Machine Torch Lead Replacement 15m (50')/TCS13	1	12.	EX-5-306-011	Standard Mounting Tube *	1
2.	EX-5-375-013	FHT-EX®105TTM Machine Torch Lead Replacement 23m (75')/TCS13	1	13.	EX-5-306-009	Short Mounting Tube	1
3.	EX-5-318-001	TCS Plug Spring Strain Relief	1	14.	EX-5-431-050	O-Ring (fitted on the torch body)	1
4.	EX-0-325-015	TCS Clam Shell Screw Kit (incl. 4 screws)	1	15.	EX-5-372-005	Torch Mounting Screws Kit (incl. 3 screws)	1
5.	EX-0-325-002	TCS Clam Shell Upper	1	16.	EX-5-372-010	Cathode Mounting Kit	1
				a 17.	EX-0-321-003	Latch w/Key Assembly	1

\* ITEMS EX-5-306-003 STANDARD MOUNTING TUBE AND EX-5-306-005 STANDARD MOUNTING TUBE REDUCTION NUT HAD BEEN REPLACED WITH THIS ITEM (EX-5-306-011) AND THEY ARE NO LONGER AVAILABLE  
**ITEM EX-5-306-004 GEAR RACK (DESIGNED FOR THE STANDARD MOUNTING TUBE EX-5-306-003) IS NO LONGER AVAILABLE.**

**a** LATCH WITH KEY IS NOT CONTENT OF TORCHES ABOVE. IF YOU NEED IT, YOU HAVE TO ORDER SEPARATELY.

Last update of this page: 10/01/2025. See Revision history for details.  
 For product availability, please check with your local THERMACUT® dealer.

# CONSUMABLES

## STANDARD MACHINE TORCH CONSUMABLES - 45-65 A

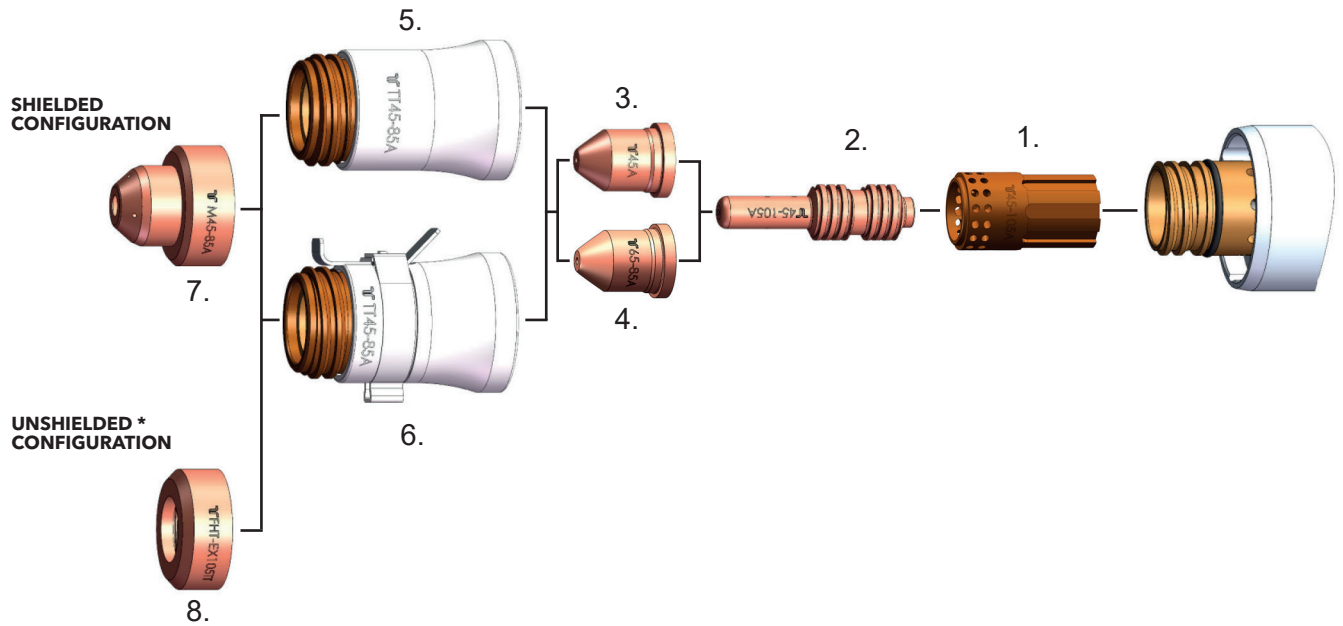

Item	Part No.	Description	Pcs	Item	Part No.	Description	Pcs
1.	EX-5-404-052	Swirl Ring 45-105 A	1	5.	EX-5-415-050	Nozzle Retaining Cap 45-85 A	1
2.	EX-5-401-051	Electrode 45-105 A	5	6.	EX-5-415-052	Nozzle Retaining Cap 45-85 A w/IHS Tab	1
3.	EX-5-410-051	Nozzle 45 A	5	7.	EX-5-422-051	Machine Shield 45-85 A	1
4.	EX-5-410-053	Nozzle 65-85 A	5	8.	EX-5-423-001	Deflector	1

\* IN COUNTRIES FOLLOWING CE STANDARDS, UNSHIELDED CONSUMABLE CONFIGURATION MAY ONLY BE USED IN MECHANIZED TORCH APPLICATIONS.

Last update of this page: 10/01/2025. See Revision history for details.  
For product availability, please check with your local THERMACUT® dealer.

# CONSUMABLES

## MACHINE TORCH CONSUMABLES - SMOOTHLINE

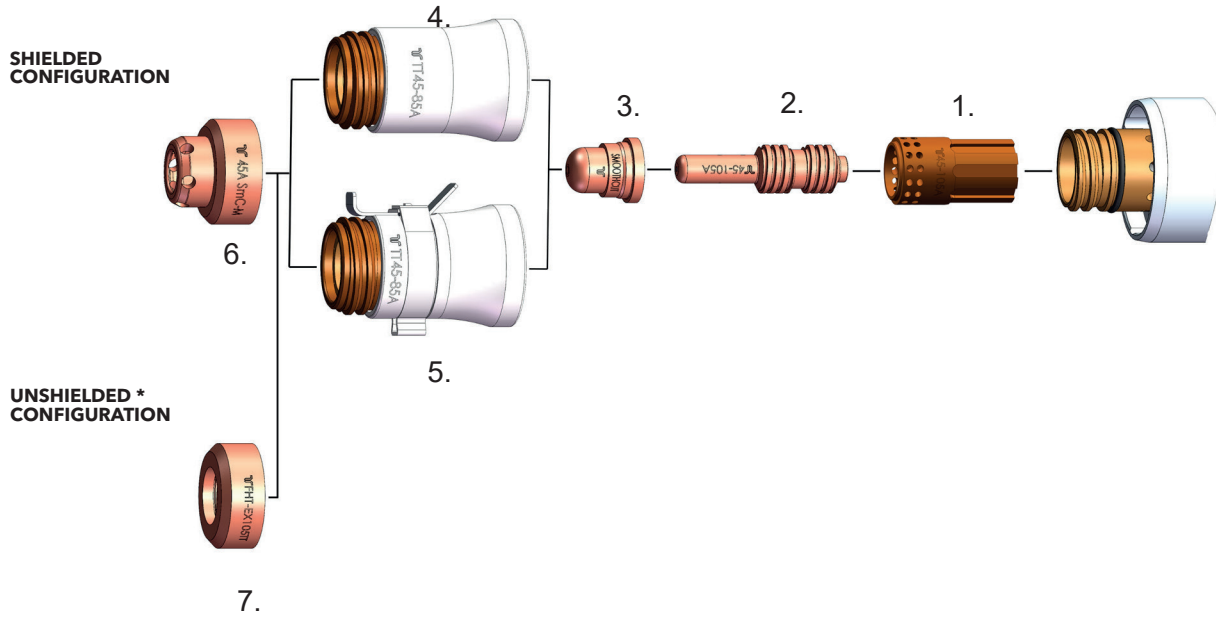

Item	Part No.	Description	Pcs	Item	Part No.	Description	Pcs
1.	EX-5-404-052	Swirl Ring 45-105 A	1	5.	EX-5-415-052	Nozzle Retaining Cap 45-85 A w/IHS Tab	1
2.	EX-5-401-051	Electrode 45-105 A	5	6.	EX-5-422-050	Machine Shield 40/45 A Smoothline	1
3.	EX-5-410-050	Nozzle Smoothline	5	7.	EX-5-423-001	Deflector	1
4.	EX-5-415-050	Nozzle Retaining Cap 45-85 A	1				

\* IN COUNTRIES FOLLOWING CE STANDARDS, UNSHIELDED CONSUMABLE CONFIGURATION MAY ONLY BE USED IN MECHANIZED TORCH APPLICATIONS.

Last update of this page: 10/01/2025. See Revision history for details.  
For product availability, please check with your local THERMACUT® dealer.

# CONSUMABLES

## MACHINE TORCH CONSUMABLES - MARKING

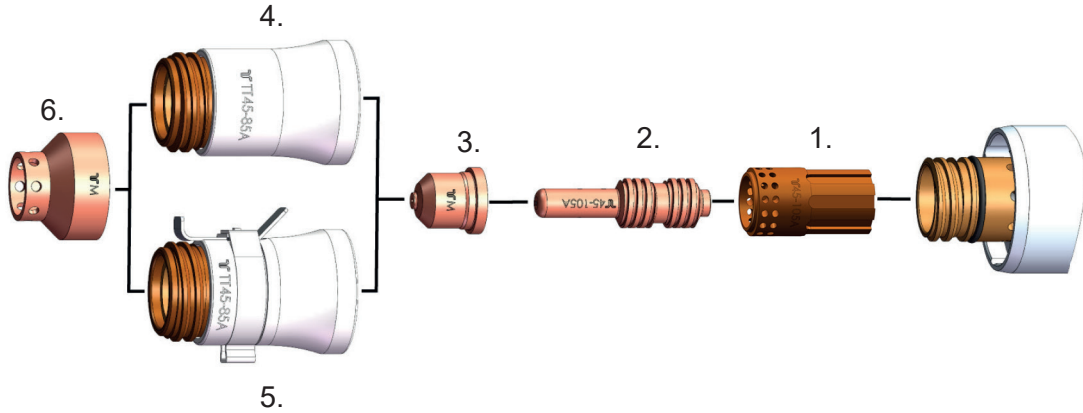

Item	Part No.	Description	Pcs	Item	Part No.	Description	Pcs
1.	EX-5-404-052	Swirl Ring 45-105A	1	4.	EX-5-415-050	Nozzle Retaining Cap 45-85A	1
2.	EX-5-401-051	Electrode 45-105 A	5	5.	EX-5-415-052	Nozzle Retaining Cap 45-85A w/IHS Tab	1
3.	EX-5-445-001	Marking Nozzle	5	6.	EX-5-445-002	Marking Shield	1

## AVAILABLE TORCH CONSUMABLE KITS FOR ASSEMBLING

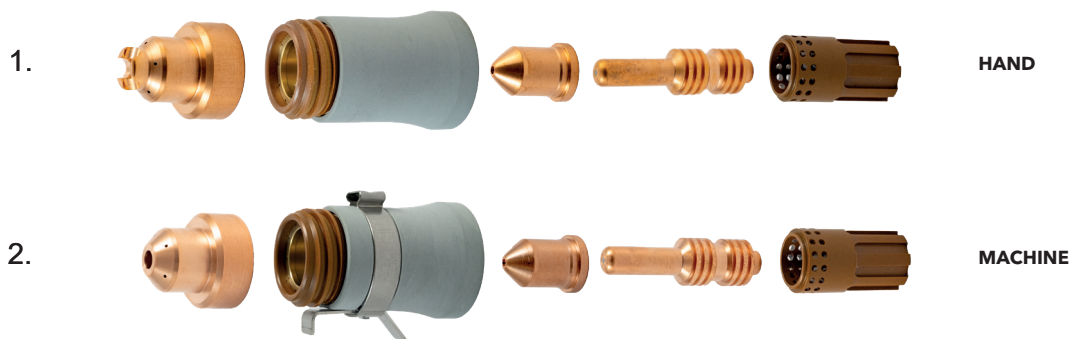

Item	Part No.	Description	Std. package QTY
1.	EX-5-439-015	H65A Consumable kit for assembling of FHT-EX®105TTH torch	1
2.	EX-5-439-010	M65A Consumable kit for assembling of FHT-EX®105TTM torch	1

Last update of this page: 10/01/2025. See Revision history for details.  
For product availability, please check with your local THERMACUT® dealer.

# CONSUMABLES

## AVAILABLE BULK PACKS



Part No.	Description	Std. package QTY
EX-5-401-061	Bulk Pack BP25 - Electrode 45-105 A	1×25



Part No.	Description	Std. package QTY
EX-5-410-060	Bulk Pack BP25 - Nozzle SmoothLine	1×25
EX-5-410-061	Bulk Pack BP25 - Nozzle 45A	1×25
EX-5-410-063	Bulk Pack BP25 - Nozzle 65-85 A	1×25



Part No.	Description	Std. package QTY
EX-5-422-041	Bulk Pack BP18 - Hand Shield 45-85A	1×18
EX-5-422-060	Bulk Pack BP18 - Machine Shield SmoothLine	1×18
EX-5-422-061	Bulk Pack BP18 - Machine Shield 45-85A	1×18

Last update of this page: 10/01/2025. See Revision history for details.  
For product availability, please check with your local THERMACUT® dealer.

# CONSUMABLES

## AVAILABLE STARTER KIT



### CONTAIN OF THE PACKAGE

- 4 pcs of electrodes
- 4 pcs of nozzles
- 4 pcs of Hand/Machine shields
- 1 pc of swirl ring
- 1 pc of torch body O-ring

Part No.	Description	Std. package QTY
EX-5-432-051	Starter Kit 65-85 A for Hand Torch FHT-EX®105TTH	1
EX-5-433-051	Starter Kit 55-65 A for Machine Torch FHT-EX®105TTM	1
EX-5-432-055	Starter Kit 45 A for Hand Torch FHT-EX®105TTH	1
EX-5-433-055	Starter Kit 45 A for Machine Torch FHT-EX®105TTM	1

Last update of this page: 10/01/2025. See Revision history for details.  
For product availability, please check with your local THERMACUT® dealer.

# ACCESSORIES



Last update of this page: 10/01/2025. See Revision history for details.

# ACCESSORIES

Item	Part No.	Ref. No.	Description	Pcs
1.	T-12452	EX-0-804-001	Filter-EX Compressed Air Filter	1
2.	T-12453	EX-0-804-002	Filter-EX Air Filter Cartridge	8
3.	EX-0-802-001	EX-0-802-001	Quick Connect Plug with male thread G 1/4" *	1
4.	EX-0-802-002	EX-0-802-002	Quick Connect Coupling with male thread G 1/4" *	1
5.	T-0994	EX-0-805-001	Silicone Lubricant 0.8 oz	1
6.	EX-2-801-001	EX-2-801-001	Circle Cut. Guide Kit for FHT-EX®30/40H	1
6.	EX-5-801-002	EX-5-801-002	Circle Cutting Guide Kit for FHT-EX®105RTXH/FHT-EX®105TTH/FHT-EX®45TTH	1
7.	EX-5-801-003	EX-5-801-003	Bevel cutting guide kit FHT-EX®105RTXH/105TTH/45TTH	1
8.	N-21811	EX-0-806-001	THERMACUT® Cutting Gloves	1
9.	EX-0-803-001	EX-0-803-001	CNC Interface 14-pin Plug Kit	1
OD	10.	EX-0-803-003	CNC Interface connection lead 3 m	1
		EX-0-803-004	CNC Interface connection lead 6 m	1
HD OD	11.	EX-0-803-006	CAN bus connection cable 10 m	1
HD		EX-0-803-007	CAN bus connection cable 5 m	1
HD OD	12.	EX-0-803-008	RS422 bus connection cable 10 m	1
HD		EX-0-803-009	RS422 bus connection cable 5 m	1
HD	13.	EX-0-803-010	Universal connection cable 10 m	1
HD OD		EX-0-803-011	Universal connection cable 5 m	1
	14.	EX-0-803-005	Plasma Arc START/STOP Remote controller for power supplies equipped with CNCinterface	1
	15.	EX-5-543-037	Work lead with clamp 300 A/4 m/16 mm²/EU-plug 35-70 mm²	1
OD		EX-5-543-003	Work lead with clamp 300 A/16 m/16 mm²/EU-plug 35-70 mm²	1
OD		EX-5-543-002	Work lead with clamp 300 A/23 m/16 mm²/EU-plug 35-70 mm²	1
OD		EX-5-543-001	Work lead with clamp 300 A/8 m/16 mm²/EU-plug 35-70 mm²	1
	16.	EX-1-543-036	Work lead with clamp 300A/4 m/10 mm²/EU-plug 10-25 mm²	1
	17.	EX-6-810-001	Hand gouging heat shield	1
	18.	EX-0-809-001	Transport case w/foam insert for EX-TRAFIRE®30H/45SD/45HD/55SD	1

**HD** FOR HD POWER SUPPLIES EQUIPPED WITH SERIAL COMMUNICATION ONLY  
**OD** ONLY ON DEMAND  
**\*** ITEMS FOR USE WITH FILTER-EX

Last update of this page: 10/01/2025. See Revision history for details.